



**BHARAT SANCHAR NIGAM LIMITED**

**A  
(Govt. of India Enterprises)  
Office of the General Manager,  
Telecom Dist-Dhenkanal-759001**

LIMITED TENDER DOCUMENT

FOR  
EARTHING OF NEW TTPS TELEPHONE EXCHANGE IN  
DHENKANAL TELECOM DISTRICT

TENDER NO OD-DKL-23/11(11)/15/2022-HR PLG - DKL OD

Dated: 28.11.2022

*Seal & Signature of Bidder*



**BHARAT SANCHAR NIGAM LIMITED**  
**O/o-The General Manager, Business Area,**  
**Dhenkanal – 759001**

**NIT No - OD-DKL-23/11(11)/15/2022-HR PLG - DKL OD Dated at Dhenkanal- 28.11.2022**  
**SECTION-I**

On behalf of General Manager Telecom District, Dhenkanal BSNL sealed Limited Tenders are invited from from bonafide and experienced contractors for DC earthing at new TTPS Telephone Exchange, under SDOT, Talcher on Job Contract Basis In Dhenkanal SSA for a period within 3 months.

Cost of bid document	Estimated cost of tender	EMD	Date and Time of		
			Issue of paper	Receipt of paper	Opening of qualifying Bid
Rs 590/- including GST	Rs.1,45,150/-	Rs. 2,903/-	28.11.2022 to 12.12.2022 (Within 12:30Hrs)	12.12.2022 up to 13:00Hrs	13.12.2022 at 11.00

**A. Eligibility criterion for the above works:**

**01.**

- a. The contractors must be bonafide and must have experience in earthing work / Electrical works / DC Earth of Equipments in BSNL/MTNL/ Central/State Govt. / anv other PSU of a minimum Rs. 1,16,000 d **OD-DKL-23/11(11)/15/2022-HR PLG - DKL OD**
- b. Experience certificate in this regard issued by an officer not below the rank of Deputy General Manager or equivalent only will be considered. Experience certificate issued by any TDE duly countersigned by an officer not below the rank of D.G.M. will also be considered.

**02. The following documents are to be enclosed with the tender document.**

- a. Attested copy of valid contractor license.
- b. Declaration of no near relative working in BSNL / MTNL.
- c. Copy of experience certificate of successfully completion of earthing works / Electrical works / DC Earth of Telephone Exchanges in BSNL/MTNL/Central/State Govt./PSU during any year, worth Rs. 1,16,000/- or more issued countersigned by an officer not below the rank of Dy. General Manager or equivalent.
- d. Bank draft towards earnest money deposit
- e. Self Attested copy of Labour license.
- f. Self Attested copy of GST registration number
- g. Valid PAN Card
- h. Declaration that the firm is not black listed by GST Authorities agreement
- i. Self Attested copy of Income TAX Return for 2020-21 and 2021-22
- j. Self attested copy of registration of firm (in case of firm)

*Seal & Signature of Bidder*

I/326223/2022

- k. Original "Power of Attorney" in case the person other than the tenderer has signed the tender documents.
- l. The tenders submitted by Partnership firms should furnish attested photocopy of "Partnership Deed" registration certificate.

**B. Bid documents can be had:**

a) From SDE(Plg), O/o GMBA, BSNL Bhawan, DKL on written application with the copies of documents in support of their eligibility to participate in the tender along with the cost of bid document as mentioned (Rs590/-) in the form of DD from any scheduled bank in favour of . **A.O (Cash), BSNL, O/o GMBA, Dhenkanal payable at Dhenkanal.**

b) The limited tender is a Two stage bidding. (In this system the outer envelope will contain two envelopes inside. One with techno-commercial bid marked as Envelope-A and and other with financial bid document marked as Envelope-B both sealed separately Eligible bidders can download the entire bid document from our website [www.odisha.bsnl.co.in](http://www.odisha.bsnl.co.in) and submit the same within scheduled time and date along with the required cost of the bid document (Rs590/-) in the form of DD from any scheduled bank in favour of **A.O (Cash), BSNL, O/o GMBA, Dhenkanal payable at Dhenkanal.** The DD and documents conforming to the eligibility criteria as mentioned in clause 'A' above are required to be kept in the "**Envelope-A: Qualifying Bid**". **The financial bid of those tenderers who qualify in the qualifying bid only will be opened by the opening committee as per time and schedule which will be intimated later. All the envelopes containing documents should be Wax / Sealed / Cello Tape sealed and names and address of the bidder should be written in the left side of each envelope.**

The detailed terms and conditions, EMD particulars etc. are available in the tender documents. Tenders without EMD will be rejected. MSE bidders are exempted from Paying the cost of Tender Documents and EMD. The GMBA Dhenkanal reserves the right to reject any or all tenders without assigning any reason thereof. The sealed tenders can be dropped in the tender box available in the chamber of **SDE (Planning), O/o GMBA, 2<sup>nd</sup> Floor, Room No.204, BSNL Bhawan, Dhenkanal.** The sealed tenders can be sent by registered post addressed to:-

**SDE (Planning),  
O/o GMBA, 2<sup>nd</sup> Floor,  
Room No.204,  
BSNL Bhawan, Dhenkanal**

Tender received through post must reach this office one day before the opening date of tender. Tender received through post in tampered condition will not be accepted.

Dy. General Manager  
O/o GMBA, DKL

*Seal & Signature of Bidder*

I/326223/2022

Passport size  
Photograph (To be  
pasted) of the  
Tendered / authorized  
Signatory holding  
Power of Attorney with  
signature on the front  
side of Photo graph  
overlapping the form

**Section-II**

**TENDERER'S PROFILE**

- 1. Name of the individual tenderer /firm .....
- 2. Name of the person submitting the tender whose photograph is affixed  
Shri / Smt .....
- (In case of proprietary /Partnership firms, the tender has to be signed by  
proprietor/partner only, as the case may be)
- 3. Address of the individual tenderer /firm  
.....  
.....
- 4. Tel. Nos. with STD code (O) .....(Fax).....(R) .....
- Mobile No ..... Email ID .....
- 5. Registration & incorporation particulars of the firm:
  - i) Proprietorship
  - ii) Partnership
  - iii) Private Limited
  - iv) Public Limited
 (Please attach attested copies of documents of registration/incorporation of your firm  
with the competent authority as required by business law)
- 6. Name of Proprietor/ Partner / Directors .....
- 7. Tenderer's bank, its address and his current account number  
.....
- 8. PAN & Income tax circle .....
- (Please attach a copy of PAN Card)

I / We hereby declare that the information furnished above is true and correct.

Place:

Date:

Signature of Tenderer / Authorised signatory .....

Name of the Tenderer .....

Seal of the Tenderer .....

*Seal & Signature of Bidder*

I/326223/2022

**SECTION-III**

***SPECIAL CUM COMMERCIAL CONDITIONS OF TENDER***

**1. Name of the Work: Earthing of exchanges to be done in the New TTPS Telephone Exchange under SDOT, Talcher of Dhenkanal Telecom District.**

**2. Approximate estimated cost of the tender Rs.1,45,150/-**

**3. N.I.T. No OD/DKL.....**

**4. EARNEST MONEY-DEPOSIT-** Earnest money as mentioned in annexure I will have to be deposited while submitting the tender, in form of demand draft drawn on any of the scheduled banks at Dhenkanal to be drawn in favour of the **A.O (Cash), BSNL O/o GMBA, Dhenkanal-759001**. The EMD shall be forfeited in case the tenderer withdraws his tender before the final acceptance or fails to enter into the prescribed agreement with BSNL for execution of work after it is accepted. EMD of unsuccessful bidders will be refunded after opening of the financial bid of the tender without any interest. For successful tenderer the EMD will to be refunded without any interest after signing the agreement & submission of Performance Bank Guarantee.

**5.(a) Validity of BID:** The bid validity period is 180 days from the date of opening of bid documents

**(b). Validity of Tender-** The tender shall remain valid for a period of 3 months from the date of signing the agreement. However GMBA Dhenkanal reserves the right to increase the period for one more year as per requirement.

**6. ELIGIBILITY CRITERION-:** *As Clause A of NIT.*

**7. SECURITY:-**

a. The successful tenderer will have to furnish 3% of the estimated value of the tender i.e. Rs. 4,355/- (Four thousand three hundred fifty five only) in the form of bank guarantee towards performance security deposit. The proceeds of the said Bank Guarantee shall be payable to the BSNL as a compensation for any loss resulting from the contractors failure to handle properly the works under the contract.

b. The security deposit in the form of Bank guarantee shall be released after six months from the date of closure contract period provided there are no recoveries to be made arising out of poor quality of work, incomplete work and/or violation of any terms and conditions of the contract as stipulated in the bid document.

c. No interest will be paid to the contractor on the above performance security deposit.

*Seal & Signature of Bidder*

I/326223/2022

## **8. Penalty Clause:**

### **For delays in the contractor's performance:**

a) The time allowed for completion of work as entered in the work order shall be strictly adhered to by the contractor and shall be reckoned from the day of issue of the work order by BSNL. The contractor shall pay as penalty an amount equal to 1 % of the amount of the work for every one week of delay in completion of work subject to a maximum of 10 % of the cost of the work awarded.

b) On any date the penalty payable as above reaches 10 % of the estimated cost of the work, the contractor should proceed with the work further only on getting a written instruction from the DE that, he is allowed to proceed with the work.

c) Penalty for delay in completion of the work shall be recoverable from the bill of the contractor and/or by adjustment from the SD or from the bill of any other contract awarded to the same party. However adjustment from SD will be made only when the contract has been terminated or at the time of final settlement of bills on completion of work.

**9.** The near relative of employees of BSNL are prohibited from participation of this tender (either directly recruited or on deputation) .The near relatives for this purpose are defined as , a) Members of Hindu undivided family b) They are husband & wife c)The one related to other in the manner as father, mother, son(s)& son's wife (daughter in law), daughter(s)& daughter's husband (son in law),brother(s) & brother's wife, sister(s) & sister's husband (brother-in law)

## **10. DOCUMENTS TO BE SUBMITTED WITH THE TENDER:**

- a. Attested copy of valid contractor license.
- b. Declaration of no near relative working in BSNL / MTNL.
- c. Copy of experience certificate of successfully completion of earthing works / Electrical works / DC Earth of Telephone Exchanges in BSNL/MTNL/Central/State Govt./PSU during any year, worth Rs. 1,16,000/- or more issued countersigned by an officer not below the rank of Dy. General Manager or equivalent.
- d. Bank draft towards earnest money deposit
- e. Self Attested copy of Labour license.
- f. Self Attested copy of GST registration number
- g. Valid PAN Card
- h. Declaration that the firm is not black listed by GST Authorities agreement
- i. Self Attested copy of Income TAX return.
- j. Self attested copy of registration of firm (in case of firm)
- k. Original "Power of Attorney" in case the person other than the tenderer has signed the tender documents.
- l. The tenders submitted by Partnership firms should furnish attested photocopy of "Partnership Deed" registration certificate.

*Seal & Signature of Bidder*

I/326223/2022

**11. ADDRESSING THE TENDER :-**

**ADDRESSING THE TENDER** –The bidders are requested to submit their bid in two different sealed cover one as “QUALIFYING BID” and the other as “FINANCIAL BID”. The qualifying bid will consist of documents Sl.No-10-1 to 10-8 & the financial bid will contain the rate quotation in the prescribed format in **ANNEXURE- VI**. Both above covers such as QUALIFYING BID and FINANCIAL BID must be kept in another third cover which also to be sealed with WAX / CELLO TAPE /Cello tape. All the three covers must be addressed to SDE (Planning), 2<sup>nd</sup> Floor, Room No.204, BSNL Bhawan, O/o GMBA, DKL and should be super scribed as “Tender for Earthing of Various Exchanges in DKL SSA” along with Tender No. and bidders name and Address. If the bidder fails to write all the above information on the bid envelope, the same may not be opened and summarily treated as rejected. The bids must be dropped in the sealed tender box kept in the office of SDE (Plg), O/o GMBA, Dhenkanal by the time mentioned in NIT.

The sealed tenders can be sent by registered post addressed to:-

**SDE (Planning),  
2<sup>nd</sup> Floor, Room No.204,  
BSNL Bhawan, O/o GMBA, DKL**

Tender received through post must reach this office before the opening date of tender & if fail to reach within the stipulated time will not be accepted. Tender received through post in tampered condition will not be accepted.

**Tenders not sealed in Wax / Cellotape will not be entertained.**

The qualifying bid will be opened on same day at 11.00 hrs in the presence of tenderers or their representatives. The financial bid of those tenderers who qualify in the qualifying bid only will be opened by the opening committee as per time schedule which will be intimated later.

**12. SPECIFICATION OF WORK (As per Diagram at Annexure-II)**

The work will be carried out as per the following specification. The scope of work includes supply of materials required for earthing, installation / commissioning at New TTPS Telephone exchange site under SDOT-Talcher of Dhenkanal Business area. The bidder has to provide Copper Plates / Flat / GI Pipes/SOLDERING STICK / COPPER BUS BAR/ BRASS NUT AND BOLT/ COPPER SOCKET(IN PCS)/ CHARCOAL (IN BAGS)/ SALT (IN KG)/ FOREIGN SOIL / OTHER MISC ITEMS while making earth at the New TTPS Exchange site with DIGGING OF PIT/ PULLING OUT WATER/ CUTTING GI PIPES/ MAKING HOLES IN PIPES/ GAS WELDING OF COPPER PLATE AND GI PIPES/ FILLING OF EARTH PITS WITH SOIL,CHARCOAL,SALT,WATERING/ LAYING OF EARTH CABLE/ MASON WORKS / FITTING OF BUS BAR,/ SOLDIRING AND TERMINATING, / TRENCHING AND LAYING EARTH LEAD WIRES UP TO EXCHANGE BUS BAR TRANSPORTATION, DISTRIBUTION, OTHER MISC WORKS as per requirement in the site.

<b>SL.NO</b>	<b>ITEMS</b>	<b>QUANTITY</b>
1	COPPER PLATES (600mmx600mmx5mm)	<b>4</b>
2	Copper flat (25mm X 5mm ) in Meter	<b>15</b>
3	GI PIPES (40mm X 10 ft ) in NO	<b>2</b>
4	SOLDERING STICK (IN KG)	<b>3</b>
5	COPPER BUS BAR(IN PCS) WITH PROCELIN MOUNTING	<b>1</b>
6	BRASS NUT AND BOLT	<b>10</b>
7	COPPER SOCKET(IN PCS)	<b>16</b>
8	CHARCOAL (IN BAGS)	<b>10</b>
9	SALT (IN KG)	<b>50</b>
10	FOREIGN SOIL IN Cft	<b>10</b>
11	OTHER MISC ITEMS	

(i) **Earth pit:** Normal depth of the earth pit will be 2mtr length X 2mtr breadth X 3mtr depth.

(ii) **Earthing Plates to be used:** 4 numbers of copper plates, two nos of G.I. pipes

(iii) **Connections:**

a) The four copper plates are to be placed at the four corners of the pit vertically & diagonally.

b) All the G.I. plates are to be connected with each other by 19/16 BTC wire by nut & bolt by using proper size of tinned Copper lug.

c) At the centre of the pit a G.I. pipe of 12ft length/ 2 inch dia. will be placed having holes at approximately 1ft. interval along with the fifth GI Plate.

d) From any two parallel cornered G.I plates interconnected by 19/16 BTC wires (terminated through nut & bolt in the concerned G.I. plate) will be taken through G.I. pipe up to exchange entrance and after that BTC wire will be taken through PVC Pipe and to be terminated in earth bus bar of the exchange.

*Seal & Signature of Bidder*

I/326223/2022

- e) One G.I. cap is to be provided at the top of the 10ft G.I. pipe (which will be used to pour water, when required).
- f) The waste water from a nearest point of the exchange is to be connected to a hole in the G.I. pipe (mentioned at 'c') by a suitable PVC pipe.
- g) After preparing the pit and arranging the materials, the connections mentioned above is to be carried out in the presence of the concerned Sub-divisional Officer (with prior information to him).
- (iv) Filling up of the pit:** The pit is to be filled up with soft soil and charcoal in layer by layer up to the ground level. The remnants around the earth pit are to be cleaned properly. The earth resistance should be less than or equal to 0.5ohms. The officer issuing the W/O must satisfy himself at least the quality of earth and take measurements after which the A/T may be conducted. All the above works to be approved and accepted by circle A/T. The materials and stores required for the job to be supplied by the contractor. The quality of the materials will be certified by the concern SDOT, Talcher.

13. Specific work will be awarded through a work order issued by the concerned authority (SDOT, Talcher) and the successful tenderer will complete each job under the said work order within the specified time given in the work order.

14. *The successful tenderers are required to submit all original documents to TOC for verification before agreement & after that they will be intimated to sign an agreement with the GMBA, Dhenkanal for carrying out the works in the tender.*

**15. Instructions to tenderer: -**

- a) The tenderer must carefully read all the terms and conditions before filling up the tender schedule.
- b) The tender should be submitted in sealed cover only and tender received in unsealed cover will be rejected summarily.
- c) The tenderer should quote rates in consolidated form taking account of all the works including supply of materials and labours.
- d). The tender submitted without EMD will be summarily rejected. No amendment to the tender in any form by the tenderer will be permitted after the submission of tender.
- f). If the tender is withdrawn after submission of the tenderer or fails to deposit the security deposit within the stipulated period, the EMD will be forfeited .
- g). Tender documents are not transferable.
- h). Rates must be quoted both in figures and words. In case of any discrepancy between figures and words, the rates quoted in words will be taken as correct in all respects. Corrections if any must be initialed by the tenderer failing, which the tender is liable to be rejected.

*Seal & Signature of Bidder*



I/326223/2022

- i). The BSNL reserves the right to award the works to more than one contractor in L1 rate only. However the decision of GMBA will be final in this regard.
- j). The validity of the tender is for three months.
- k). Each tender must be accompanied by EMD which shall be deposited in shape of Demand Draft / Bankers Cheque drawn from any Scheduled Bank payable at Dhenkanal in favour of A.O (Cash), BSNL, O/o the GMBA, Dhenkanal. The EMD deposited by other means apart from those as mentioned above, will not be accepted. Late tender will not be accepted.
- l). The department shall not take any liability of the person / persons employed by the contractor for their future employment in the department.
- m). Canvassing directly or indirectly will be treated as a disqualification
- n). Any tender received in the tender box unsealed will not be opened or considered.
- o). Tender documents should be signed by the tenderer on each page.
- p). In case of unscheduled holiday on the closing / opening date, the next working day will be treated as scheduled closing / opening date of the tender.
- q). Incomplete tender form will be summarily rejected without assigning any reason.
- r). Specific work will be awarded through a work order issued by the concerned SDOP/SDOT and the successful tenderer will complete each job under the said work order within the specified time.
- s). A committee will be appointed by GMBA, Dhenkanal to evaluate the tender. The criteria of selection will be strictly on the basis of all rates quoted.
- t). The GMBA Dhenkanal reserves the right to forfeit the S.D of the approved contractor who does sub-standard work or refuses to work and also reserve the right to with held payment if any for the said reason.
- u). In case any dispute arises, the decision of the GMBA, Dhenkanal will be final and binding on all tenderers.
- v). The successful tenderers will be required to abide by labour laws enacted from time to time by central / state Govt. Maintenance/ observation of any/ or all the statutory labour laws will be the sole responsibility of the successful tenders. Claims arising out of injury causality or any of the workmen employed by the Contractor will be the sole responsibility of the successful tenderer. GMBA Dhenkanal will not entertain any claim or damage in this regard, he should comply with all the requirement of the contract labour regulation and control act and obtain license accordingly.

*Seal & Signature of Bidder*

I/326223/2022

w). The BSNL will not be responsible to pay for the additional works carried out without taking prior sanction of the competent authority.

**16. Payment: -**

a). Payment for execution of work will be made by BSNL only after satisfactory completion of the work as per the constructional standard subject to the issue of the certificate from the SDE/SDO concerned regarding satisfactory completion of the work dully countersigned by the DE concerned and after acceptance of A/T. No payment for incomplete works will be considered.

b). The contractor may submit bills in duplicate along with (i) Work Order, (ii) Material Account statement and (iii) MB based on the joint measurements recorded in the M.B. and signed by the contractor, SDE concerned in each page of the M.B. The M.B. must contain the dates of commencement and completion of the work and other particulars of the work in detail. The bill must be properly certified by the controlling officer and countersigned by concern D.E. Details of all statutory payments like GST should also be attached alongwith the bill.

c). 100% payment will be done after production of bill as per 16(b) above.

d). Payment will be made through E-Payment. The contractor will have to furnish the Bank A/c No. (Core Banking) in the front of bill.

e). Sales tax, Income tax and other taxes if any will be recovered from each bill preferred by the contractor. This is subject to change as and when required under statutory rules. However the service tax and cess (If required) will be charged extra by the contractor at the time of producing bills.

**17. Signing of the Contract Agreement: -**

a). The successful tenderer after submission of Bank guarantee as performance security deposit will be required to sign a contract agreement bond (as enclosed with tender document) with BSNL on non-judicial stamped paper of Rs. 100/- at his own cost within the time specified from the date of issue of offering letter, failing which the earnest money will be forfeited.

b). In case the successful bidder refuses to do the job or fails to sign the agreement within the stipulated period, then the authority reserves the right to award the same work to other contractors, in full or in parts without any liability or loss suffered / likely to be suffered by the bidder(s) in the said contract including forfeiture of the EMD/SD money deposited.

**18. Sub-Contractors: -**

The contractor shall not assign, subcontract or sublet the whole or any part of the work covered by the contract. Incase it is proved that the tenderer has engaged subcontractors the tender awarded in his favour would be treated as null and void and SD will be forfeited.

*Seal & Signature of Bidder*

I/326223/2022

**19. Rescission/Termination of contract**

Under following conditions the competent authority may rescind/terminate the contract.(a)If the contractor suspends the execution of work &the engineer in charge of the work comes to judgment that the work could not be completed by the due date or the contractor had already failed to complete the work by that date.(b) If the contractor had been given by the officer in charge of work a notice in writing to rectify/replace any defective work fails to comply with the requirement within a period of seven days from the date of receipt of such notice & (c) If the contractor commits breach any item of conditions in the contract or sublets without prior permission.

Before determining/rescinding, the Engineer in charge shall first give show cause notice. Thereafter Notice on Final Action will have to be served in case no response is received for first show cause notice.

**20. FORCE MAJEURE:**

a). If any time, during the continuance of this contract, the performance in whole or in part by either party of any obligation under this contract shall be prevented or delayed by reason of any war, or hostility, acts of the public enemy, civil commotion, sabotage, fires, floods, explosions, epidemics, quarantine restrictions, strikes, lockouts or act of God (Hereinafter referred to as events) provided notice of happenings, of any such eventuality is given by either party to the other within 21 days from the date of occurrence thereof, neither party shall by reason of such event be entitled to terminate this contract nor shall either party have any such claim for damages against the other in respect of such non-performance or delay in performance, and deliveries under the contract shall be resumed as soon as practicable after such event may come to an end or cease to exist, and the decision of the Contractor as to whether the works have been so resumed or not shall be final and conclusive, provided further that if the performance, in whole or part of any obligation under this contract is prevented or delayed by reason of any such event for a period exceeding 60 days either party may, at his option terminate the contract.

b). PROVIDED also that if the contract is terminated under this clause, the Department shall be at liberty to take over from the contractor at a price to be fixed by the Department, which shall be final, all unused, undamaged and acceptable materials, bought out components and stores in the course of execution of contract in possession of the contractor at the time of such termination of such portion thereof as the Department may deem fit excepting such materials bought out components and stores as the contracts may with the concurrence of the Department elect to retain.

*Seal & Signature of Bidder*

I/326223/2022

**21. ARBITRATION:**

- a. In the event of any question, dispute or difference arising under this agreement or in connection there with except as to matter the decision of which is specifically provided under this agreement, the same shall be referred to sole arbitration of the General Manager, Telecom District, BSNL, Dhenkanal or in case his designation is changed or his office is abolished then in such case to the sole arbitration of the Officer for the time being entrusted whether in addition to the functions of the General Manager, Telecom District, BSNL, Dhenkanal or by whatever designation such officers may be called (hereinafter referred to as the said officer) and if the General Manager, Telecom District, BSNL, Dhenkanal or the said officer is unable or unwilling to act as such the sole arbitration or some other person appointed by the General Manager, Telecom District, BSNL, Dhenkanal or the said officer. The agreement to appoint an arbitrator will be in accordance with the Arbitration and Conciliation Act, 1996.

There will be no objection to any such appointment that the arbitrator is Government Servant or that he has to deal with the matter to which the agreement relates or that in the course of his duties as Government Servant he has expressed views on all or any of the matter under dispute. The award of the arbitrator shall be final and binding on the parties. In the event of such arbitrator to whom the matter is originally referred, being transferred or vacating his office or being unable to act for any reasons whatsoever such General Manager, Telecom District, BSNL, Dhenkanal or the said officer shall appoint another person to act as arbitrator in accordance with terms of the agreement and the person so appointed shall be entitled to proceed from the stage at which it was left out by his predecessors.

- b. The arbitrator may from time to time with the consent of parties enlarge the time for making and publishing the award. Subject to aforesaid Arbitration and Conciliation Act; 1996 and the Rules made there under, any modification thereof for the time being in force shall be deemed to apply to the arbitration proceeding under this clause.

- c. The venue of the arbitration proceeding shall be the Office of the Chief General Manager, Odisha Telecom, Dhenkanal or such other places as the arbitrator may decide.

*Seal & Signature of Bidder*

I/326223/2022

**22. SET OFF:**

Any sum of money due and payable to the Contractor (including Security deposit refundable to him) under this contract may be appropriated by the Purchaser or the BSNL or any other person or persons contracting through the BSNL, India and set off the same against any claim of the Purchaser or BSNL or such other person or person(s) for payment of a sum of money arising out of this contract or under any other contract made by the Contractor with the Purchaser or BSNL or such other person(s) contracting through BSNL, India.

**23. Indemnities: -**

a. The contractor shall at all times hold he BSNL harmless and indemnify from against all actions, suits, proceeding, work, cost, damages, charges, claims and demands of every nature and descriptions brought or procured against BSNL, its officers and employees and forthwith upon demand and without protest or demur to pay to the BSNL any and all losses and damages and cost (inclusive between attorney and client) and all costs incurred in endorsing this or any other indemnity or security which the BSNL may now or at any time have relative to the work or the contractor's obligations or in protecting or charges and expenses and liabilities resulting from or incidental or in connection with injury, disease or disablement to or death of any person(s) including employees of the contractor or damage to property resulting from or arising out of or in any way connection with or incidental to the operations caused by the contract documents, in addition the contractor shall reimburse the BSNL or pay to the BSNL for the wit on demand without protest or demur all cost, charges and expenses and losses and damages otherwise incurred by it in consequence of any claims, demands and actions which may be brought against the BSNL arising connection with or incidental to the operations caused by the contract documents, in addition the contractor shall reimburse the BSNL or pay to the BSNL for the wit on demand without protest or demur all cost, charges and expenses and losses and damages otherwise incurred by it in consequence of any claims, demands and actions which may be brought against the BSNL arising out or incidental to or in connection with the operation covered by contract.

b. The contractor shall at his own cost and at the BSNL request defend any suit or other proceedings arresting a claim covered by this indemnity, but shall not settle, compound or compromise any suit or other findings without first consulting the BSNL.

*Seal & Signature of Bidder.*

I/326223/2022

**SECTION- IV****CHECK LIST**

SI No.	Description	Remarks
1.	Whether the following papers are enclosed?	YES or NO
a)	Attested copy of valid contractor license.	
b)	Declaration stating that non of his family member or near relatives working in BSNL.(Proforma to be filled up as given in Annexure –3 ).	
c)	Copy of experience certificate of successfully completion of earthing works / Electrical works / DC Earth of Telephone Exchanges in BSNL/MTNL/Central/State Govt./PSU during any year, worth Rs. 1,16,000/- or more issued countersigned by an officer not below the rank of Dy. General Manager or equivalent.	
d)	EMD, as per Annexure-I of the document.	
e)	Self Attested Photo copy of valid Labour license.	
f)	Self Attested copy of GST registration number	
g)	Self Attested copy of IT Return for the Year 2020-21 & 2021-22	
h)	PAN Number (Attested Copy)	
i)	Original “Power of Attorney” in case person other than the tenderer has signed the tender documents must be submitted along with bid document.	
j)	The tenders submitted by Partnership firms should furnish attested photocopy of “Partnership Deed" duly registered.	
k)	Tenderer’s profile duly filled in, as per section-II of the tender document.	
l)	Tender document(s), in original, duly filled in and signed by tenderer or his authorized representative along with seal on each page. All corrections and overwriting must be initialed with date by the tenderer or his authorized representative.	
m)	Whether the tender has been sealed properly? (WAX/ Cellotape).	
n)	Whether the corrections if any has been encircled and fresh entry mode and signed by the authorized signatory? (No over writing is permissible).	
o)	Whether your tender is conditional? ( All conditional tender will be rejected.)	
p)	Whether you have super scribed on the envelope the name of the tender.	
q)	Original “Power of Attorney” in case the person other than the tenderer has signed the tender documents.	
r)	The tenders submitted by Partnership firms should furnish attested photocopy of “Partnership Deed" registration certificate.	

N: B – Document are to be submitted as per serial order of the check list.

*Seal & Signature of Bidder*

I/326223/2022

**Annexure-1****EARTHING OF EXCHANGE : NEW TTPS Telephone Exchange under SDOT, Talcher of  
Dhenkanal BA. :**

<b>Sl.No.</b>	<b>Name of RSUs</b>	<b>E.M.D.</b>
01.	<b><u>NEW TTPS Telephone Exchange under SDOT, Talcher</u></b>	Rs. 2,903/-

The earthing works in each Exchange will be supervised by concerned SDOT- Talcher

*Seal & Signature of Bidder*

**EXCHANGE EARTHING (LAYOUT & INTERCONNECTION)**

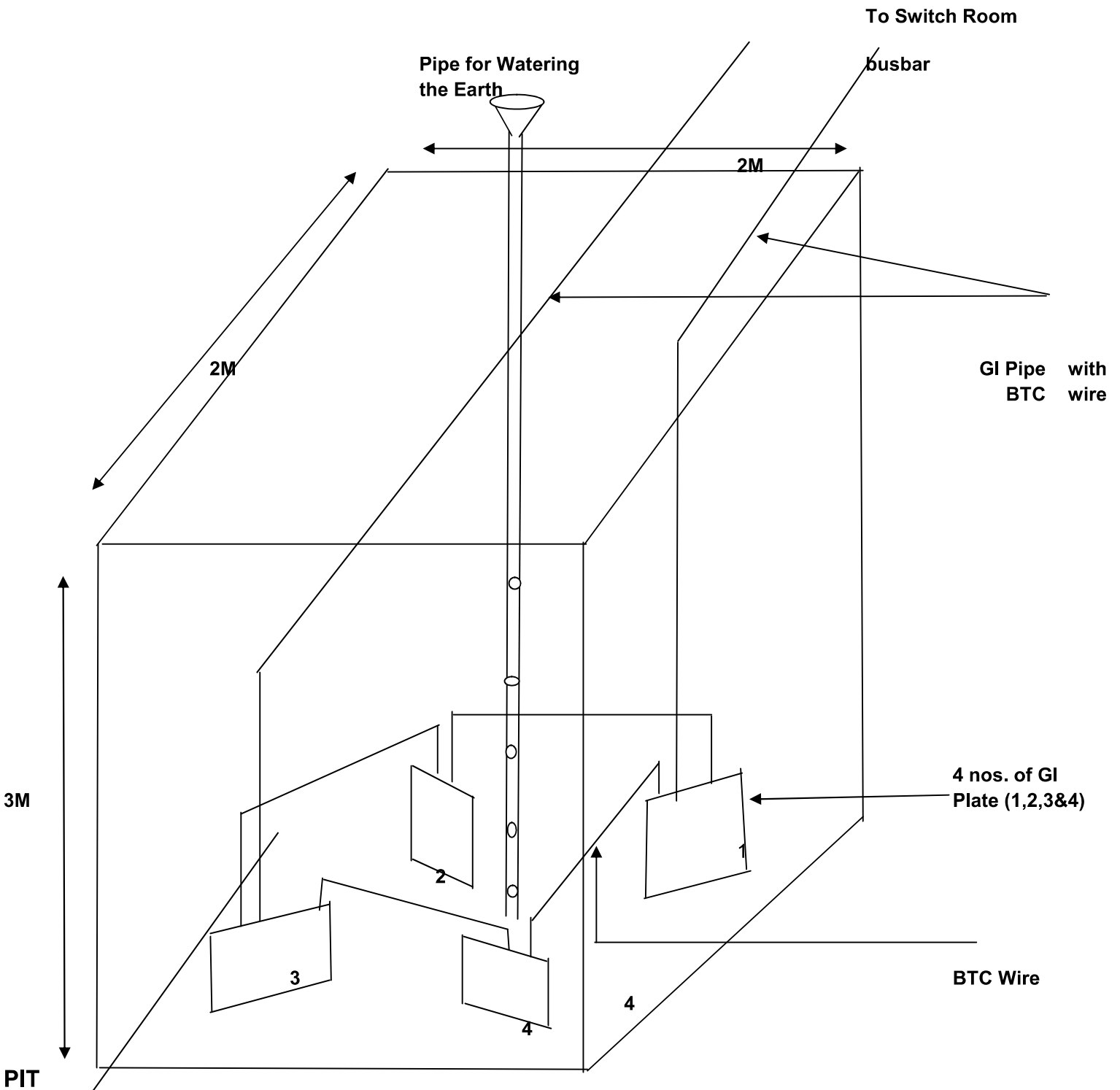

- i) 1,2,3,4 All the above are GI Plates.
- ii) All the GI plates will be welded with the BTC wire as shown in the diagram.
- iii) The pit will be of 2mtr\*2mtr\*3mtr'
- iv) The BTC wire to be terminated to exchange bus bar should be enclosed with GI Pipe.
- v) The pit will be filled by charcoal, sand and salt in appropriate quantity.

*Seal & Signature of Bidder*  
*Page-16*



I/326223/2022

ANNEXURE-III

**PROFORMA FOR NO NEAR RELATIVES CERTIFICATE IN BSNL**

[Certificate to be given by the contractor in respect of no near relative (s) in BSNL of the contractor.]

DECLARATION

I,.....

S/o.....resident of  
.....hereby certify that none of my near relative(s) as defined in the tender document is/are employed any where in BSNL as per details given in tender document. In case at any stage, it is found that the information given by me is false/incorrect, BSNL shall have the absolute right to take any action as deemed fit, without any prior intimation to me.

Signature of the bidder

**Note: The near relatives for this purpose are defined as :**

- A. Members of a Hindu Undivided family.
- B. They are husband and wife.
- C. The one is related to the other in the manner as father, mother, son(s) and son's wife (Daughter-in-law). Daughter(s) and daughter's husband (Son-in-law), Brother(s) and brother's wife, sister(s) and sister's husband (Brother-in-law.)

Note: In case of proprietorship firm, certificate will be given by the proprietor, for partnership firm, certificate will be given by all the partners and in case of Private Ltd. Company, by all the directors of the company.

Signature of the Tenderer

Name of the Contractor.

(Capacity in which signing)

Place:

Date:

*Seal & Signature of Bidder*

I/326223/2022

**ANNEXURE-IV**

**AGREEMENT FORM**

An agreement is entered into between the General Manager Telecom Dist. Dhenkanal representing B.S.N.L. and \_\_\_\_\_ (Contractor) this day of \_\_\_\_\_ for doing earthing works. Whereas in response to the Tender Notice No----- for doing earthing works.

Shri \_\_\_\_\_ has agreed to carry out the said work under the terms and conditions fixed for the successful tenderer for a period of one year.

Further Sri \_\_\_\_\_ declared as approved contractor allotted to \_\_\_\_\_ under the GMBA, Dhenkanal and accepted by him.

\_\_\_\_\_ further undertakes to abide by the terms and conditions as prescribed in the approved tender.

\_\_\_\_\_ further agrees that in the case he fails to carry out and complete the said work within the specified time given in work order, he shall have no claim for refund of Security Deposit and he shall be liable to bear with the loss sustained by the B.S.N.L. thereby.

Contractor

Signature

**Dy. General Manager (Planning)**

Signature

**O/o GMBA, Dhenkanal**

Name:

Name

Address:

Address

Witness

Witness

Name &Address

Name & Address

Witness

Name &Address

Signature of the Tendered.

Date:

*Seal & Signature of Bidder*

**ANNEXURE-V**

**PERFORMANCE SECURITY GUARANTEE (Bond Form) for tender No N-95/10-11/dtd30-04-11**

1. **In consideration of the General Manager Telecom District, Bharat Sanchar Nigam Limited** (hereinafter called the 'BSNL') having agreed to exempt .....{hereinafter called "the said Contractor(s)} from the demand, under the terms and conditions of ..... an agreement / (Purchase Order) No.....dated.....made between .....and .....for the supply of .....{hereinafter called "the said AGREEMENT"} of Security Deposit for the due fulfillment by the said Contractor(s) of the terms and conditions contained in the said Agreement, of production of the Bank Guarantee for .....we (name of the Bank) .....(hereinafter referred to as "the Bank") at the request of .....Contractor(s) do hereby undertake to pay to the BSNL an amount not exceeding .....against any loss or damage caused to or suffered or would be to or suffered by the BSNL by reason of any breach by the said Contractor(s) of any of the terms or conditions contained in the said Agreement.
  
2. We (name of the Bank) .....do hereby undertake to pay the amounts due and payable under this Guarantee without any demur, merely on a demand from the BSNL stating that the amount claimed is due by way of loss or damage caused to or would be caused to or suffered by the BSNL by reasons of breach by the said contractor(s) of any of the terms or conditions contained in the said agreement. Any such demand made on the Bank shall be conclusive as regard the amount due and payable by the Bank under this Guarantee where the decision of the BSNL in these counts shall be final and binding on the bank. However, our liability under this Guarantee shall be restricted to an amount not exceeding .....
  
3. We undertake to pay the BSNL any money so demanded not withstanding any dispute or disputes raised by the Contractor(s) / Contractor (s) in any suit or proceeding pending before any court or Tribunal relating thereto our liability under this present being obsolete and unequivocal. The payment so made by us under this bond shall be valid discharge of our liability for payment there under and the contractor(s) / Contractor(s) shall have no claim against us for making such payment.

*Seal & Signature of Bidder*

I/326223/2022

4. WE (name of the Bank) .....further agree that the Guarantee therein contained shall remain in full force and effect during the period that would taken for the performance of the said agreement and that it shall continue to be enforceable till all the dues of the BSNL under or by the virtue of the said agreement have been fully paid and its claims satisfied or discharged or till ----- (Office / Department ) (BSNL) \_\_\_\_\_ certifies that the terms and conditions of the said agreement have been fully and properly carried out by the Contractor(s) and accordingly discharges this Guarantee. Unless a demand or claim under this Guarantee is made on us in writing on or before **the expiry of Eighteen months** (as stipulated in PO) from the date thereof, we shall be discharged from all liabilities under this Guarantee thereafter.

5. We (name of the Bank) \_\_\_\_\_ further agree with the BSNL that the BSNL shall have the fullest liberty without our consent and without affecting in any manner our obligations hereunder to vary any of the terms and conditions of the said agreement or to extend time of performance by the said Contractor (s) from time to time or to postpone for any time or from time to time any of the powers exercisable by the BSNL against the said Contractor (s) and to forbear or enforce any of the terms and conditions relating to the said agreement and we shall not be relieved from our liability by reason or any such variation, or extension being granted to the said Contractor (s) or by any such matter or thing whatsoever which under the law relating to the sureties would, but for this provision, have effect of so relieving us.

6. This guarantee will not be discharged due to change in the Constitution of the Bank or the Contractor (s) / Contractor (s).

7. We (name of the Bank) ..... lastly undertake not to revoke this Guarantee during its currency except with the previous consent of the BSNL in writing.

Dated the ..... Day of .....2011

*Seal & Signature of Bidder*

I/326223/2022

**ANNEXURE-VI****FINANCIAL BID**

(Tender Paper No. \_\_\_\_\_ )

**To**

**The General Manager,  
Telecom District, Dhenkanal.**

***Sub- : Financial bid for the Earthing works***

Dear Sir,

Having examined the tender documents terms and conditions stipulated therein specification of works etc.I/We, the undersigned offer to execute the Earthing work of exchanges in Dhenkanal telecom district in conformity with the said specifications and conditions of contract at the rates quoted as under.

Rates in Figure	Rates in Words	Remark
		The rates includes all the work done with all the materials as per clause 12 & 15 (c ) and the diagram at Annexure-2, inclusive of all taxes.

Name &amp; Address of the tenderer.

***Seal & Signature of Bidder***

I/326223/2022

**Annexure-VII**

**Format for Declaration for EMD/Bid security exemption by MSE Bidder.**

**Tender for “EARTHING OF NEW TTPS TELEPHONE EXCHANGE” in Dhenkanal SSA**

To

The GM, BA, Dhenkanal

**SUB: BID SECURITY/EMD UNDERTAKING & DECLARATION**

**(As per the BSNL CO Ltr No. BSNLCO-MMT/12(15)/1/2020-MMT dated 05-12-20)**

I / we \_\_\_\_\_do hereby undertake & declare that under any / all of the below conditions / circumstances, BSNL reserves the **right to forfeit / cancel** our **bid / EOI / Purchase Order / Work Order** if any issued, and also can **suspend / debar / Ban** for a period of **1(one) year** from the date of issue of such order for any further work / contract.

**Conditions / Circumstances:**

1. If I / we withdraw or amend the bid or impairs or derogates from the bid in any respect during the period of bid validity specified by the bidder in the bid form.
2. If I / we do not accept the APO/AWO/PO/WO and/or do not submit the PBG and/or fail to sign the contract / agreement and/or fail to commence the work in time as per BSNL order.
3. If any loss or damage caused to or would be caused to or suffered by the BSNL by reason of breach of any of terms / conditions contained in the said tender document or by reason of any failure to perform the said Agreement by me / us.
4. If anything is found false and/or incorrect and/or reveals any suppression of fact at any time,
5. If subsequently I / we fail to obey any of the contractual obligations w.r.t work awarded by BSNL.

I/We do hereby submit an unqualified and unconditional declaration cum undertaking that, I am an eligible vendor for Tender No. .... for EARTHING OF NEW TTPS TELEPHONE EXCHANGE under SDOT, Talcher of Dhenkanal SSA, and I have submitted valid MSE Udyam Regd. Certificate indicating URM No:..... (Udyam Registration Certificate) from MSME in order to avail the benefit in available to MSEs

This Declaration is being submitted in lieu of EMD/Bid Security

Read, understood and agreed

Date: ..... Signature of Bidder.....

Place: ..... Name of Bidder.....

Date & Seal of the Bidder

*Seal & Signature of Bidder*